

# STA-RITE®

## MAX-E-PRO™ CENTRIFUGAL PUMPS WITH INTEGRAL TRAP

O W N E R ' S M A N U A L

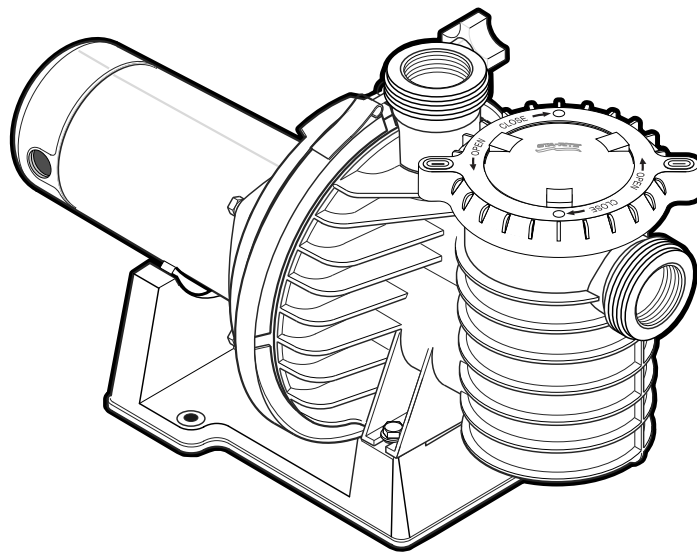

---

INSTALLATION, OPERATION & PARTS

**Series P6E and P6RA**

*See Page 2 for Model Numbers*

This manual should be furnished to the end user of this pump; its use will reduce service calls and chance of injury and will lengthen pump life.

---

### Sta-Rite Pool/Spa Group

293 Wright Street, Delavan, WI 53115

International: 262-728-5551, FAX: 262-728-7550

www.starite.com

Union City, TN • Delavan, WI • Mississauga, Ont. • Murrieta, CA

© 2003, Sta-Rite Industries, Inc.

Printed in U.S.A.

S691 (Rev. 10/30/03)

## **'P6RA' and 'P6E' SERIES PUMP WITH TRAP**

To avoid unneeded service calls, prevent possible injuries, and get the most out of your pump, READ THIS MANUAL CAREFULLY!

The Sta-Rite 'P6RA' and 'P6E' Series Self-priming Centrifugal pumps:

- Are designed for use with swimming pools or as centrifugal pumps.
- Are excellent performers; durable, reliable.

### **Table of Contents**

Safety Instructions .....	3
Installation.....	4-6
Electrical.....	6-8
Operation .....	9-10
Storage/Winterizing .....	10
Pump Service.....	11-12
Troubleshooting Guide .....	13
Repair Parts List .....	14-15
Warranty.....	16

<b>Max-E-Pro™ Pump Models</b>			
<b>HP</b>	<b>2-Speed</b>		
1/2	P6E6C-204L		
3/4	P6E6D-205L		
1	P6E6E-206L	P6RA6E-205L	
1-1/2	P6E6F-207L	P6RA6F-206L	P6RA6YF-206L
2	P6E6G-208L	P6RA6G-207L	P6RA6YG-207L
3	P6E6H-209L		

# IMPORTANT SAFETY INSTRUCTIONS

Always follow basic safety precautions with this equipment, including the following.

**▲ WARNING** To reduce the risk of injury, do not permit children to use this product unless they are closely supervised at all times.

**▲ CAUTION** This pump is for use with permanently installed pools and may also be used with hot tubs and spas if so marked. Do not use with storable pools. A permanently installed pool is constructed in or on the ground or in a building such that it cannot be readily disassembled for storage. A storable pool is constructed so that it may be readily disassembled for storage and reassembled to its original integrity.

## SAVE THESE INSTRUCTIONS

## READ AND FOLLOW SAFETY INSTRUCTIONS!

**▲** This is the safety alert symbol. When you see this symbol on your system or in this manual, look for one of the following signal words and be alert to the potential for personal injury.

**▲ DANGER** warns about hazards that **will** cause death, serious personal injury, or major property damage if ignored.

**▲ WARNING** warns about hazards that **can** cause death, serious personal injury, or major property damage if ignored.

**▲ CAUTION** warns about hazards that **will** or **can** cause minor personal injury or property damage if ignored.

**NOTICE** indicates special instructions not related to hazards.

**Carefully read and follow all safety instructions in this manual and on equipment.** Keep safety labels in good condition; replace if missing or damaged.

**▲ WARNING** **Incorrectly installed or tested equipment may fail, causing severe injury or property damage.**  
**Hazardous pressure** Read and follow instructions in owner's manual when installing and operating equipment. Have a trained pool professional perform all pressure tests.

1. Do not connect system to a high pressure or city water system.
2. Use equipment only in a pool or spa installation.
3. Install pump with at least 2 hydraulically balanced main drains equipped with correctly installed, screw-fastened, anti-entrapment certified covers. See Page 5.
4. Trapped air in system can cause explosion. BE SURE all air is out of system before operating or testing equipment.

**Before pressure testing, make the following safety checks:**

- Check all clamps, bolts, lids, and system accessories before testing.
- Release all air in system before testing.
- Water pressure for test must be less than 25 PSI (7.5 kg/cm<sup>2</sup>).
- Water Temperature for test must be less than 100° F. (38° C).
- Limit test to 24 hours. After test, visually check system to be sure it is ready for operation. Remove trap lid and retighten hand tight only.

**NOTICE:** These parameters apply to Sta-Rite equipment only. For non-Sta-Rite equipment, consult manufacturer.

## INSTALLATION

**Only qualified, licensed personnel should install pump and wiring.**

**Pump mount must:**

Be located away from corrosive or flammable chemicals.

**NOTICE:** Port threads are: Internal - 2" NPT for direct connection to pipe. External - 3-1/4" Buttress. Fits Sta-Rite U11-200P Union Collar for quick disconnect pipe connection.

See Page 14 for Union Kits.

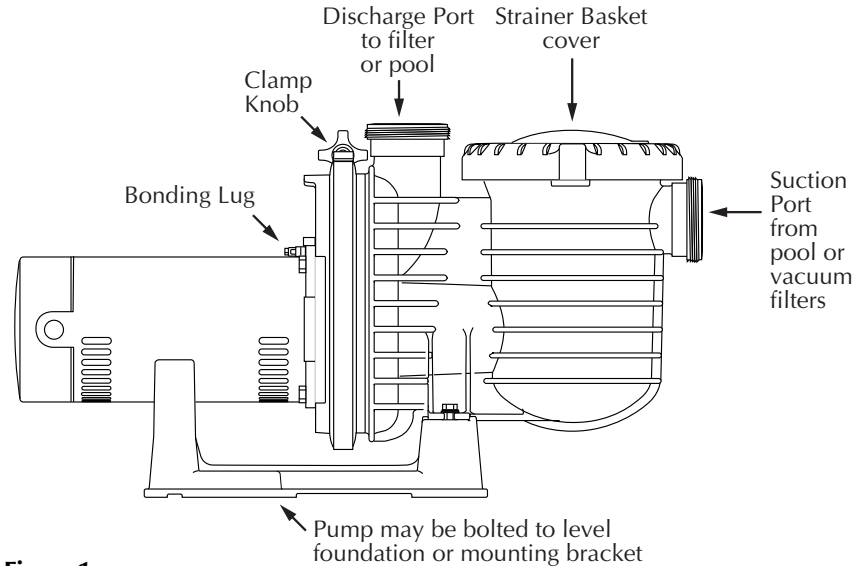

**Figure 1**

Have enough ventilation to maintain air temperature at less than the maximum ambient temperature rating (Max. Amb.) listed on the motor model plate. If this pump is installed in an enclosure/pump house, the enclosure must have adequate ventilation and air circulation to keep the temperature in the enclosure at or below the motor's rated ambient temperature whenever the pump is running.

Be solid - Level - Rigid - Vibration free - Non-combustible. (To reduce vibration and pipe stress, bolt pump to mount.)

Allow pump suction inlet height to be as close to water level as possible.

Allow use of short, direct suction pipe (To reduce friction losses).

Allow for gate valves in suction and discharge piping.

Have adequate floor drainage to prevent flooding.

Be protected from excess moisture.

Allow adequate access for servicing pump and piping.

**⚠ WARNING Fire and burn hazard.** Modern motors run at high temperatures. To reduce the risk of fire, do not allow leaves, debris, or foreign matter to collect around the pump motor. To avoid burns when handling the motor, let it cool for 20 minutes before trying to work on it.

**NOTICE:** Use Teflon tape or Plasto-Joint Stik<sup>1</sup> for making all threaded connections to the pump. Do not use pipe dope; pipe dope will cause stress cracking in the pump.

**NOTICE:** Pump suction and discharge connections have molded in thread stops. DO NOT try to screw pipe in beyond these stops.

### Teflon Taping Instructions:

Use only new or clean PVC pipe fittings.

Wrap male pipe threads with one to two layers of Teflon tape. Cover entire threaded portion of pipe.

**Do not** overtighten or tighten past thread stop in pump port!

If leaks occur, remove pipe, clean off old tape, rewrap with one to two additional layers of tape and remake the connection.

**NOTICE:** Support all piping connected with pump!

<sup>1</sup>Lake Chemical Co., Chicago, Illinois

## Piping:

Use at least 2" IPS PVC (51mm) pipe. Increase size if a long run is needed.  
To avoid strains on the pump, support both suction and discharge pipes independently. Place these supports near the pump.  
To avoid a strain left by a gap at the last connection, start all piping at the pump and run pipe **away** from the pump.  
Never use a suction pipe smaller than pump suction connection.  
To avoid airlocking, slope suction pipe slightly upward toward the pump.  
**NOTICE:** To prevent flooding when removing pump for service, all flooded suction systems **must** have gate valves in suction and discharge pipes.

## Fittings:

Fittings restrict flow; for best efficiency use fewest possible fittings.  
Avoid fittings which could cause an air trap.  
Pool fittings must conform to International Association of Plumbing and Mechanical Officials (IAPMO) standards.  
Use only non-entrapping suction fitting or double suction.

# POOL PUMP SUCTION REQUIREMENTS

**⚠ WARNING** Pump suction is hazardous and can trap and drown or disembowel bathers. Do not use or operate swimming pools, spas, or hot tubs if a suction outlet cover is missing, broken, or loose. Follow the guidelines below for a pump installation which minimizes risk to users of pools, spas, and hot tubs.

## Entrapment Protection

The pump suction system *must* provide protection against the hazard of suction entrapment or hair entrapment/entanglement.

## Suction Outlet Covers

All suction outlet covers must be maintained. They must be replaced if cracked, broken, or missing.

See below for outlet cover certification requirements.

All suction outlets must have correctly installed, screw-fastened covers in place.

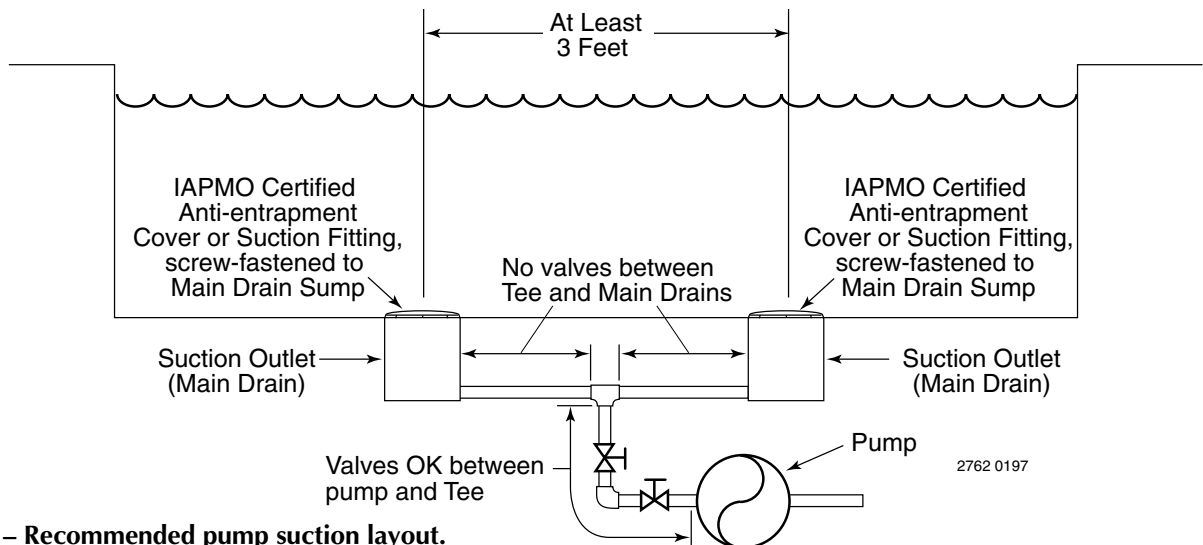

Figure 2 – Recommended pump suction layout.

## Testing and Certification

Suction outlet covers must have been tested by a nationally recognized testing laboratory and found to comply with the latest ASME/ANSI Specification for *Suction Fittings For Use in Swimming Pools, Spas, Hot Tubs, and Whirlpool Bathtub Applications*.

## Outlets Per Pump

Provide at least two hydraulically balanced main drains, with covers (see Page 5), for each swimming pool pump suction line. The centers of the main drains (suction fittings) must be at least three feet apart.

The system must be built so that it cannot operate with the pump drawing water from only *one* main drain (that is, there must be at least two main drains connected to the pump whenever it is running). (See Figure 2). However, if two main drains run into a single suction line, the single suction line may be equipped with a valve which will shutoff *both* main drains from the pump (see Figure 2).

More than one pump can be connected to a single suction line as long as the requirements above are met.

## Water Velocity

The maximum water velocity through any suction outlet must be 1.5 feet per second unless the outlet complies with the latest ASME/SNSI Specification for *Suction Fittings For Use in Swimming Pools, Spas, Hot Tubs, and Whirlpool Bathtub Applications*. In any case, do not exceed the suction fittings maximum designed flow rate.

If 100% of the pump's flow comes from the main drain system, the maximum water velocity in the pump suction hydraulic system must be six feet per second or less even if one main drain (suction fitting) is completely blocked. The flow through the remaining main drain(s) must comply with the latest ASME/ANSI Specification for *Suction Fittings For Use in Swimming Pools, Spas, Hot Tubs, and Whirlpool Bathtub Applications*.

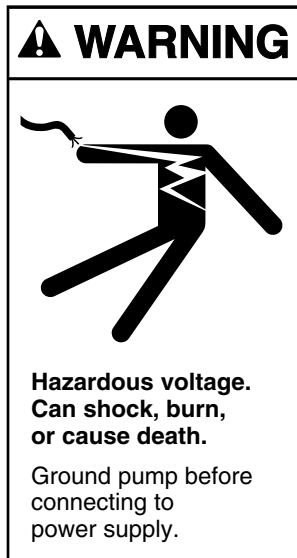

## ELECTRICAL

- ⚠ Ground motor before connecting to electrical power supply. Failure to ground motor can cause severe or fatal electrical shock hazard.**
- ⚠ Do not ground to a gas supply line.**
- ⚠ To avoid dangerous or fatal electrical shock, turn OFF power to motor before working on electrical connections.**
- ⚠ Ground Fault Circuit Interrupter (GFCI) tripping indicates an electrical problem. If GFCI trips and will not reset, have a qualified electrician inspect and repair electrical system.**
- ⚠ Exactly match supply voltage to nameplate voltage. Incorrect voltage can cause fire or seriously damage motor and voids warranty. If in doubt consult a licensed electrician.**

## Voltage

Voltage at motor must be not more than 10% above or below motor nameplate rated voltage or motor may overheat, causing overload tripping and reduced component life. If voltage is less than 90% or more than 110% of rated voltage when motor is running at full load, consult power company.

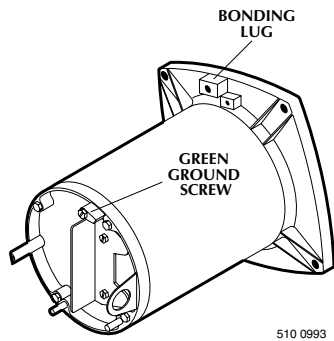

Figure 3: Typical ground screw and bonding lug locations.

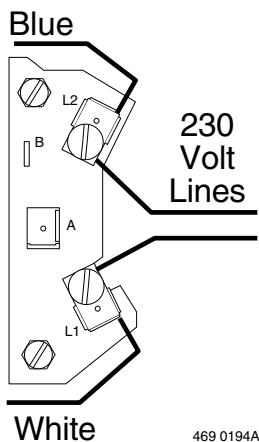

Figure 4A: Single-phase, single speed wiring connection diagram. For 3-phase connection, refer to motor nameplate.

## Grounding/Bonding

Install, ground, bond and wire motor according to local or National Electrical Code requirements.

Permanently ground motor. Use green ground terminal provided under motor canopy or access plate (See Figure 3); use size and type wire required by code. Connect motor ground terminal to electrical service ground.

Bond motor to pool structure. Use a solid copper conductor, size No. 8 AWG (8.4 sq.mm) or larger. Run wire from external bonding lug (see Figure 3) to reinforcing rod or mesh.

Connect a No. 8 AWG (8.4 sq.mm) solid copper bonding wire to the pressure wire connector provided on the motor housing and to all metal parts of the swimming pool, spa, or hot tub and to all electrical equipment, metal piping or conduit within 5 feet (1.5 m) of the inside walls of swimming pool, spa, or hot tub.

## Wiring

Pump must be permanently connected to circuit. See Figures 4A and 4B for wiring connection diagrams. Match wire and circuit breaker sizes to correct Fusing and Wiring Data Chart (Page 8). If other lights or appliances are also on the same circuit, be sure to add their amp loads to pump amp load. (If unsure how to do this or if this is confusing, consult a licensed electrician.) Use the load circuit breaker as the master on-off switch.

Install a Ground Fault Circuit Interrupter (GFCI) in circuit; it will sense a short-circuit to ground and disconnect power before it becomes dangerous to pool users. For size of GFCI required and test procedures for GFCI, see manufacturer's instructions.

In case of power outage, check GFCI for tripping (which will prevent normal water circulation). Reset if necessary.

**NOTICE:** If you do not use conduit when wiring motor, **be sure** to seal wire opening on end of motor to prevent dirt, bugs, etc., from entering motor.

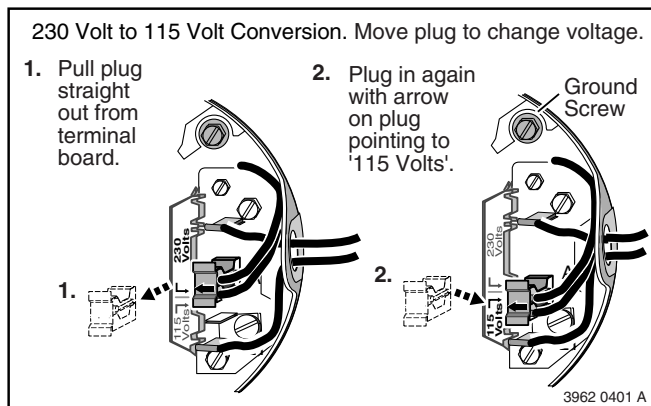
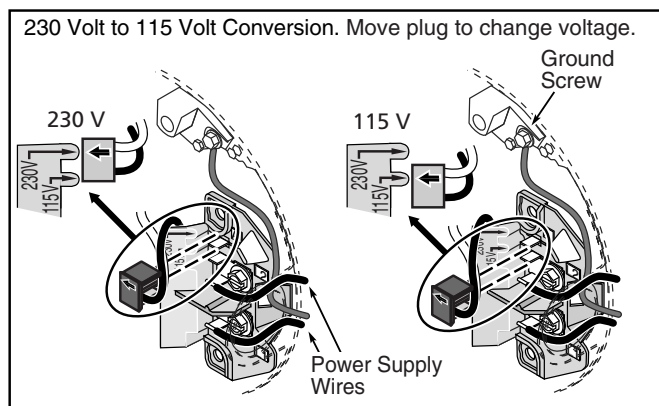

Figure 4B: Wiring connections for plug-in type terminal board (Single speed, single phase motors)

**TABLE I - RECOMMENDED FUSING AND WIRING DATA – P6E MODELS**

Motor HP	Branch Fuse Rating Amps*	Max Load Amps	Voltage/ Hz/Phase	Serv. to Motor - Dist. in Ft. (M)			Wire Size AWG (mm <sup>2</sup> )
				0-100' (0-30 M)	101-200' (30-60 M)	201-300' (60-90 M)	
<b>P6E Models:</b>							
1/2	15	11.0	115/60/1	14(2)	10(5.5)	8(8.4)	}
3/4	20	13.8	115/60/1	12(3)	10(5.5)	8(8.4)	
1	25	16.0	115/60/1	12(3)	8(8.4)	6(14)	
1/2	15	5.5	230/60/1	14(2)	14(2)	14(2)	
3/4	15	6.9	230/60/1	14(2)	14(2)	14(2)	
1	15	8.0	230/60/1	14(2)	14(2)	14(2)	
1-1/2	15	10.4	230/60/1	14(2)	12(3)	12(3)	
2	15	11.2	230/60/1	14(2)	12(3)	12(3)	
3	25	15.8	230/60/1	12(3)	12(3)	10(5.5)	

\* Time delay fuses are recommended instead of standard fuses in any motor circuit.

**TABLE II - RECOMMENDED FUSING AND WIRING DATA – P6RA MODELS**

Motor HP	Branch Fuse Rating Amps*	Max Load Amps	Voltage/ Hz/Phase	Serv. to Motor - Dist. in Ft. (M)			Wire Size AWG (mm <sup>2</sup> )	
				0-100' (0-30 M)	101-200' (30-60 M)	201-300' (60-90 M)		
<b>P6RA Models:</b>								
1	20/15	15.3/7.6	115/230/60/1	12/14(3/2)	8/14(8.4/2)	6/14(14/2)	}	
1-1/2	30	19.2	115/60/1	10(5.5)	8(8.4)	6(14)		
1-1/2	15	9.6	230/60/1	14(2)	14(2)	12(3)		
2	15	12.0	230/60/1	14(2)	14(2)	12(3)		
<b>P6RA 2-Speed Models:</b>								
1-1/2	15	9.2/2.5	230/60/1	14(2)	14(2)	12(3)		
2	15	10.1/3.7	230/60/1	14(2)	14(2)	12(3)		

\* Time delay fuses are recommended instead of standard fuses in any motor circuit.



**⚠ CAUTION**



## OPERATION

**⚠ NEVER run pump dry.** Running pump dry may damage seals, causing leakage and flooding. Fill pump with water before starting motor.

**⚠ Before removing trap cover:**

1. **STOP PUMP** before proceeding.
2. **CLOSE GATE VALVES** in suction and discharge pipes.
3. **RELEASE ALL PRESSURE** from pump and piping system.
4. **NEVER tighten or loosen clamp while pump is operating!**

**⚠ If pump is being pressure tested, be sure pressure has been released before removing trap cover.**

**⚠ Do not block pump suction. To do so with body may cause severe or fatal injury.** Small children using pool must **ALWAYS** have close adult supervision.

**⚠ WARNING Fire and burn hazard.** Modern motors run at high temperatures. To reduce the risk of fire, do not allow leaves, debris, or foreign matter to collect around the pump motor. To avoid burns when handling the motor, let it cool for 20 minutes before trying to work on it. An automatic internal cutoff switch protects the motor from heat damage during operation.

**NOTICE:** Maximum ambient temperature for motor operation must not exceed maximum ambient temperature rating on motor model plate.

### Priming Pump

Release all pressure from filter, pump, and piping system; see the filter owner's manual.

In a flooded suction system (water source higher than pump), pump will prime itself when suction and discharge valves are opened.

If pump is not in a flooded suction system, remove trap cover handle ring and trap cover; fill trap and pump with water.

Do not lubricate the trap cover O-Ring. The original equipment O-Ring contains a permanent internal lubricant.

**NOTICE:** If you replace the O-Ring with a non-internally lubricated O-Ring, you may need to apply a silicone based lubricant.

Clean and inspect O-Ring; reinstall on trap.

Replace trap cover and handle ring on trap; turn handle ring clockwise to tighten cover.

**NOTICE:** Tighten trap cover handle ring by hand only (**no wrenches**)! Pump should prime now. Priming time will depend on vertical length of suction lift and horizontal length of suction piping.

If pump does not prime, make sure that all valves are open, suction pipe end is under water, and that there are no leaks in suction pipe.

See Troubleshooting Guide, Page 13.

### Routine Maintenance

The only routine maintenance needed is inspection/cleaning of trap basket. Debris or trash that collects in basket will choke off water flow through the pump. Follow instructions below to clean trap:

1. Stop pump, close valves in suction and discharge, and **release all pressure from system before proceeding.**

2. Remove trap cover handle ring (turn counterclockwise). If necessary, tap handles gently with a rubber mallet.
3. Remove strainer basket and clean. Be sure all holes in basket are clear, flush basket with water and replace in trap with large opening at pipe connection port (between ribs provided). If basket is replaced backwards cover will not fit on trap body.
4. Clean and inspect lid O-Ring; reinstall on trap.
5. Clean O-Ring groove on trap body and replace cover and handle ring. To help keep cover from sticking, tighten **hand tight only**.
6. Prime pump (see priming instructions).

### Draining Pump

1. Pump down water level below all inlets to the pool.

**⚠ WARNING** To avoid dangerous or fatal electrical shock hazard, turn OFF power to motor before draining pump.

2. Remove trap cover and use low pressure air to blow accumulated water from the piping system. Lugs have been provided on the trap lid to use a lever or pry bar for loosening.
3. Cap inlet piping after draining to keep water out of the pipes.
4. To prevent pump from freezing, remove trap cover and drain the tank body through the drain plugs (Key No. 19, Pages 14 - 18). Clean pump and trap basket thoroughly; replace trap cover.  
**NOTICE:** Tighten trap cover by hand only (**no wrenches**)! Use a rubber mallet only if necessary to remove cover! If pump is not anchored, use caution not to break attached piping!
5. Be sure motor is kept dry and covered.

### Storage/Winterizing:

**⚠ WARNING** Explosion hazard. Purging the system with compressed air can cause components to explode, with risk of severe injury or death to anyone nearby. Use only a low pressure (below 5 PSI), high volume blower when air purging the pump, filter, or piping.

**NOTICE:** Allowing pump to freeze will damage pump and void warranty!

**NOTICE: Do not** use anti-freeze solutions (except propylene glycol) in your pool/spa system. Propylene glycol is non-toxic and will not damage plastic system components; other anti-freezes are highly toxic and may damage plastic components in the system.

Drain all water from pump and piping when expecting freezing temperatures or when storing pump for a long time (see instructions below).

Keep motor dry and covered during storage.

To avoid condensation/corrosion problems, **do not** cover pump with plastic.

For outdoor/unprotected installations:

1. Gravity drain system as far as possible.
2. Protect areas which retain water with non-toxic propylene glycol antifreeze ("RV antifreeze").
3. Enclose entire system in a weatherproof enclosure.
4. To avoid condensation/corrosion damage, allow ventilation; **do not** wrap system in plastic.
5. Use a 40% propylene glycol/60% water solution to protect pump to -50°F (-46°C).

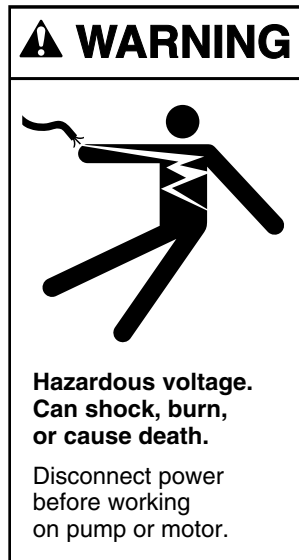

## Startup For Winterized Equipment

1. Remove any temporary weather protection placed around system.
2. Follow filter manufacturer's instructions for reactivation of the filter.
3. Inspect all electrical wiring for damage or deterioration over the shutdown period. Have a qualified serviceman repair wiring as needed.
4. Inspect and tighten all watertight connections.
5. Open all valves in suction and return piping.
6. Remove any winterizing plugs in piping system.
7. Drain all antifreeze from system.
8. Close all drain valves and replace all drain plugs in piping system.
9. Prime pump according to instructions on Page 9.

## PUMP SERVICE

**Pump should only be serviced by qualified personnel.**

**For best results, use only genuine Sta-Rite factory parts.**

**Be sure to prime pump (Page 9) before starting.**

**⚠ CAUTION**

**⚠ Before removing clamp or trap cover:**

1. **STOP PUMP** before proceeding.
2. **CLOSE GATE VALVES** in suction and discharge pipes.
3. **RELEASE ALL PRESSURE** from pump and piping system.
4. **NEVER** tighten or loosen clamp while pump is operating!

**⚠ To avoid dangerous or fatal electrical shock hazard, turn OFF power to motor before working on pump or motor.**

No lubrication or regular maintenance is needed beyond reasonable care and periodic cleaning of strainer basket.

If shaft seal is worn or damaged, repair as follows:

### Pump Disassembly/Removing Old Seal

**Disconnect power to pump motor.**

**⚠ Be sure** gate valves on suction and return piping are closed before starting work.

Release all pressure by opening all vents before starting work.

1. Drain pump by removing drain plugs on bottom of pump body and trap body.
2. **Be sure** there is no pressure in trap body; remove cover (unscrew by turning handle ring counterclockwise).
3. Remove clamp holding pump halves together. Motor and seal plate assembly can now be pulled away from pump body.
4. Remove five screws and washers holding diffuser to seal plate. Remove diffuser.
5. Remove motor canopy. Being careful not to touch capacitor terminals, loosen capacitor clamp and move capacitor to one side.
6. Hold shaft with 7/16" open-end wrench on motor shaft flats.



7. Unscrew impeller from shaft (turn counterclockwise when facing it).  
**NOTICE:** On models with impeller screw: Remove impeller screw (left hand thread - turn **clockwise**) and gasket before removing impeller. Inspect gasket for damage, cracks, etc. Replace if damaged.
8. Pull rotating member of seal off of impeller sleeve; clean sleeve.
9. Remove four screws holding seal plate to motor.
10. Place seal plate face down on flat surface and tap out ceramic seat.
11. Clean seal cavity in seal plate and clean motor shaft.

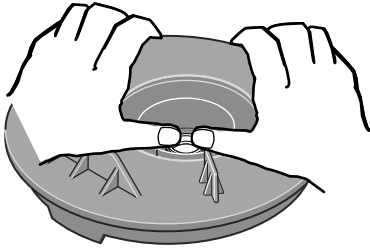

Figure 5: Press seal into seal plate

### Pump Reassembly/Installing New Seal

1. Ceramic seat must be clean and free of dirt, grease, dust, etc. Wet outer edge of rubber cup on ceramic seat with small amount of liquid detergent; press ceramic seat into seal plate firmly and squarely with finger pressure (Figure 5).
  2. If ceramic seat will not locate properly, remove it, place **face up** on bench and reclean cavity. Ceramic seat should now locate.
  3. If seat still will not locate properly, place a cardboard washer over the polished face and use a piece of 3/4" (19mm) standard pipe for pressing purposes. **NOTICE: Be sure** not to scratch or mar polished surface or seal will leak.
  4. Remount seal plate on motor. Tighten bolts to 60-80 inch-lbs. (69-92 kg/cm) torque.
  5. Apply a **small** amount of liquid detergent to inside diameter of rotating half of seal.
  6. Slide rotating seal member, polished face last, over impeller sleeve until rubber drive ring hits shoulder.  
**NOTICE: Be sure** not to nick or scratch polished seal face; seal will leak if face is damaged.
  7. Screw impeller onto shaft (clockwise); this will automatically locate seal in seal plate.  
**NOTICE:** On models with impeller screw: Install impeller gasket and lock screw (left-hand thread - turn **counterclockwise**). Torque lock screw to 50-55 inch-lbs. (57.6-63 kg/cm).
  8. Mount diffuser on seal plate; tighten screws to 10-14 inch-lbs. (11.2-16.1 kg/cm) torque.
  9. Assemble motor and seal plate to volute; be sure clamp is properly seated.  
**NOTICE:** Clamp knob can be located in any position around volute; if it is moved after assembly, tighten knob while tapping around clamp to assist sealing. Do not move clamp while pump is full of water.
- ▲ WARNING** Hazardous pressure. Release all pressure from pump and piping system before working on pump or attempting to adjust or remove clamp. Clamp may blow off of pump if adjusted under pressure.
10. Prime pump according to instructions on Page 9.

## TROUBLESHOOTING GUIDE

**⚠ Read and understand safety and operating instructions in this manual before doing any work on pump!**

**⚠ Only qualified personnel should electrically test pump motor!**

### FAILURE TO PUMP; REDUCED CAPACITY OR DISCHARGE PRESSURE

#### Suction leaks/lost prime:

1. Pump must be primed; make sure that pump volute and trap are full of water. See priming instructions, Page 9.
2. Make sure there are no leaks in suction piping.
3. Make sure suction pipe inlet is well below the water level to prevent pump from sucking air.
4. Suction lift of 10 to 20 feet (3-6 M) will reduce performance. Suction lift of more than 20 feet (6 M) will prevent pumping and cause pump to lose prime. In either case, move pump closer (vertically) to water source. Make sure suction pipe is large enough.

#### Clogged pipe/trap/impeller, worn impeller:

5. Make sure suction trap is not clogged; if it is, clean trap and strainer.
6. Make sure impeller is not clogged (follow steps 1 through 7 under "Removing Old Seal", Page 11; check impeller for clogging; follow steps 7 through 10 under "Installing New Seal", Page 12, for reassembly).
7. Impeller and diffuser may be worn. If so, order replacement parts from Repair Parts List, Pages 14-15.
8. Pump may be trying to push too high a column of water. If so, a "higher head" pump is needed.

#### Electrical:

9. Pump may be running too slowly; check voltage at motor terminals and at meter while pump is running. If low, see wiring instructions or consult power company. Check for loose connections.
10. Pump may be too hot.
  - A. Check line voltage; if less than 90% or more than 110% of rated voltage consult a licensed electrician.
  - B. Increase ventilation.
  - C. Reduce ambient temperature.
  - D. Tighten any loose connections.

#### MECHANICAL TROUBLES AND NOISE

1. If suction and discharge piping are not adequately supported, pump assembly will be strained. See "Installation", Page 4.
2. Do not mount pump on a wooden platform! Securely mount on concrete platform for quietest performance.



## REPAIR PARTS LIST

Key No.	Part Description	Qty.	Part No.
1	Motor	1	Chart at Right
2	#10-32x1/2" Screw	1	U30-692SS
2A	Lock Washer	1	U43-22SS
3	Bonding Lug	1	U17-568
4	Water Slinger	1	17351-0009
5	Seal Plate Kit (Incl. Key Nos. 6, 7)	1	C203-194P
6	O-Ring	1	U9-228A
7	Shaft Seal	1	37400-0028S
8	Clamp Knob	1	C19-37A
9	Clamp	1	WC36-22
10	Impeller	1	Chart at Right
10A	Impeller Screw O-Ring	1	35505-1426
10B	Impeller Screw	1	Chart at Right
11	Diffuser	1	Chart at Right
12	Diffuser O-Ring	1	U9-374
13	#8 Lock Washer	5	U43-21SS
14	Screw (w/C1-271P Diffuser)	5	U30-922SS
14	Screw (w/C1-271P1 Diffuser)	5	U30-542SS
15	Tank Body Assembly****	1	17307-0110S
16	Trap Cover Assembly**	1	17307-0111S
17	Trap O-Ring	1	35505-1440
18	Basket	1	C8-58P
19	1/4" NPT Drain Plug	2	U178-920P
20	Base Washer	2	U43-41SS
21	Base Screw	2	U30-918SS
22	Base w/Motor Pad***	1	C104-78P
23	Motor Pad	1	C35-43
24	3/8-16x1" Hex Hd. Screw	4	U30-74SS
•	Voltage Sticker - 230 Volts (Single voltage models only)		U27-68
•	Voltage Sticker - 115/230 Volts (Dual voltage models only)		U27-153
•	Tag, "CAUTION, WARNING (bonding)"		61002-0002
•	Decal, "Do not overtighten..."		U27-644
•	Nameplate		32155-7117

• Not illustrated.

\*\* Includes Trap Cover, Trap Ring and Trap Cover O-Ring.

\*\*\* Model P6E6H uses Base No. C104-79P and Motor Pad No. C35-44.

\*\*\*\* Includes Trap Body, Basket, Drain Plugs, and Trap Cover Assembly.

## P6E, P6RA MAX-E-PRO™ POOL PUMP 1/2 through 3 HP Models

### Box A

For quick disconnect pipe connections, purchase separately:  
Pkg. 188 2" Slip 1/2 Union Kit or  
Pkg. 189 2" NPT 1/2 Union Kit.

Includes 2 each:  
U11-200P Union Collar  
U9-362 O-Ring  
U11-196P 2" Slip adapter or  
U11-199P 2" NPT adapter.

**Parts are common to all models listed except as noted;**

Key Nos. 1, Motor; 10, Impeller; and 11, Diffuser are listed below.

Model No.	HP	Motor No. (Key No. 1)	Impeller (Key No. 10)	Diffuser (Key No. 11)
<b>115/230 Volt</b>				
P6E6C-204L	1/2	AE100CHL	C105-238PX	C1-271P1
P6E6D-205L	3/4	AE100DHL	C105-238P	C1-271P1
P6E6E-206L	1	AE100EHL	C105-238PB	C1-271P1
P6RA6E-205L	1	A100ELL	C105-238P	C1-271P1
P6RA6F-206L	1½	A100FLL	C105-238PB	C1-271P1
<b>230 Volt</b>				
P6E6F-207L*	1½	AE100FHL	C105-238PDBA	C1-271P
P6E6G-208L*	2	AE100GHL	C105-238PEBA	C1-271P
P6RA6G-207L*	2	A100GHL	C105-238PDBA	C1-271P
P6E6H-209L*	3	AE100HLL	C105-238PLA	C1-271P
<b>2-Speed</b>				
P6RA6YF-206L**	1½-1/4	A100FLL-Y	C105-238PBA	C1-271P
P6RA6YG-207L*	2-1/3	A100GLL-Y	C105-238PDBA	C1-271P

\*Uses Key No. 10B Impeller Screw No. 37337-6080.

\*\* Uses Key No. 10B Impeller Screw No. 37337-6081.

# P6E, P6RA MAX-E-PRO™ POOL PUMP 1/2 through 3 HP Models

□

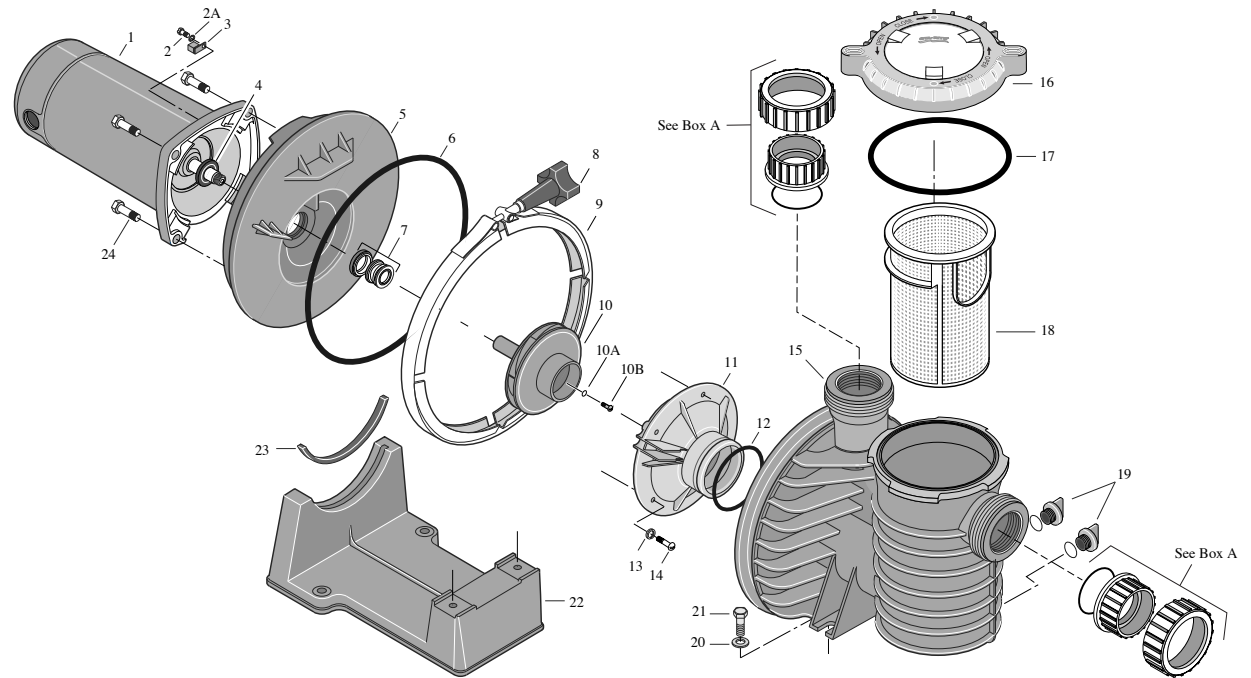

## STA-RITE LIMITED WARRANTY

Pumps, filters, skimmers, underwater lights (except bulbs), accessories and fittings manufactured by Sta-Rite are warranted to be free of defects in material and workmanship for one (1) year from date of installation.

**Product specific warranties:** **Year from date of installation**

<i>HRPB, DEPB, System 3, System 2 and Posi-Clear</i>	
Tanks .....	10 years
Internal filter components and valves .....	1 year
<i>Max-E-Therm - Pool/Spa Heaters</i> .....	
Heater Enclosure only (Upper RH & LH; lower enclosure; and control board enclosure)...	10 years
<i>Automatic Pool Cleaners including Hose</i> .....	2 years
<i>Cristal-Flo filters - Tanks</i> .....	
Valve and internal components. ....	1 year
<i>Posi-Flo II - Tanks</i> .....	
Elements .....	1 year
<i>PRC Cartridge -</i>	
Filter Tanks .....	5 years pro-rated (1st 2 years full)
Elements .....	1 year
<i>System 2 Above Ground Systems - Tanks</i> .....	
Pumps / Platform and Internals .....	1 year
<i>Pumps</i> .....	
When equipped with A.O. Smith 2-compartment motors (Does not include pumps sold as part of a systems package) .....	2 years
<i>Traps / In-Line Strainers</i> .....	1 year
<i>Vertical Commercial Filter - Tanks</i> .....	
Internals .....	1 year
<i>Horizontal Commercial Filter</i>	
Tanks .....	5 years (Years 6-9, Prorated declining 20%/year, Yr. 10 - 10%)
Internals .....	1 year

\* Full warranty coverage is in effect for one year after installation. The pro-rated warranty covers the *tank only* during the 2nd through 10th year after installation. The amount covered decreases by 10% each year. (ie., 2nd year 90% covered, 3rd year 80% covered, etc.).

The foregoing warranties relate to the original consumer purchaser ("Purchaser") only. Sta-Rite shall have the option to repair or replace the defective product, at its sole discre-

tion. Purchasers must pay all labor and shipping charges necessary to replace the product covered by this warranty. Requests for warranty service must be made through the installing dealer. This warranty shall not apply to any product that has been subject to negligence, misapplication, improper installation or maintenance, or other circumstances which are not in Sta-Rite's direct control.

This warranty sets forth Sta-Rite's sole obligation and Purchaser's exclusive remedy for defective products.

STA-RITE SHALL NOT BE LIABLE FOR ANY CONSEQUENTIAL, INCIDENTAL OR CONTINGENT DAMAGES WHATSOEVER.

THE FOREGOING WARRANTIES ARE EXCLUSIVE AND IN LIEU OF ALL OTHER EXPRESS WARRANTIES. IMPLIED WARRANTIES, INCLUDING BUT NOT LIMITED TO THE IMPLIED WARRANTIES OF MERCHANTABILITY AND FITNESS FOR A PARTICULAR PURPOSE, SHALL NOT EXTEND BEYOND THE DURATION OF THE APPLICABLE EXPRESS WARRANTIES PROVIDED HEREIN.

Some states do not allow the exclusion or limitation of incidental or consequential damages or limitations on how long an implied warranty lasts, so the above limitations or exclusion may not apply to you. This warranty gives you specific legal rights and you may also have other rights which vary from state to state.

Supersedes all previous publications.

**Sta-Rite Industries, Inc.,**  
**293 Wright St., Delavan, WI 53115**

▲ **Retain Warranty Certificate (upper portion) in a safe and convenient location for your records.**

*DETACH HERE: Fill out bottom portion completely and mail within 10 days of purchase/installation to:*

▼ **Sta-Rite, Attn: Warranty Dept., 293 Wright St., Delavan, WI 53115**

**STA-RITE®**



## Warranty Registration Card

Name \_\_\_\_\_

Years pool has been in service  less than 1  1-3  3-5  5-10 \_\_\_\_\_

Address \_\_\_\_\_

Purchased from:  
 Company name \_\_\_\_\_

City \_\_\_\_\_ State \_\_\_\_\_ Zip \_\_\_\_\_

Address \_\_\_\_\_

Purchase Date \_\_\_\_\_

City \_\_\_\_\_ State \_\_\_\_\_ Zip \_\_\_\_\_

Product Purchased \_\_\_\_\_

New installation  Replacement \_\_\_\_\_

**Please send me more information on these other products from Sta-Rite.**

Type of Pool  Inground  Vinyl  Fiberglass  Gunite \_\_\_\_\_

- Pumps  Filters  Automatic Pool Cleaners
- Maintenance Equipment  Test Strips
- Heaters

Size of Pool \_\_\_\_\_